

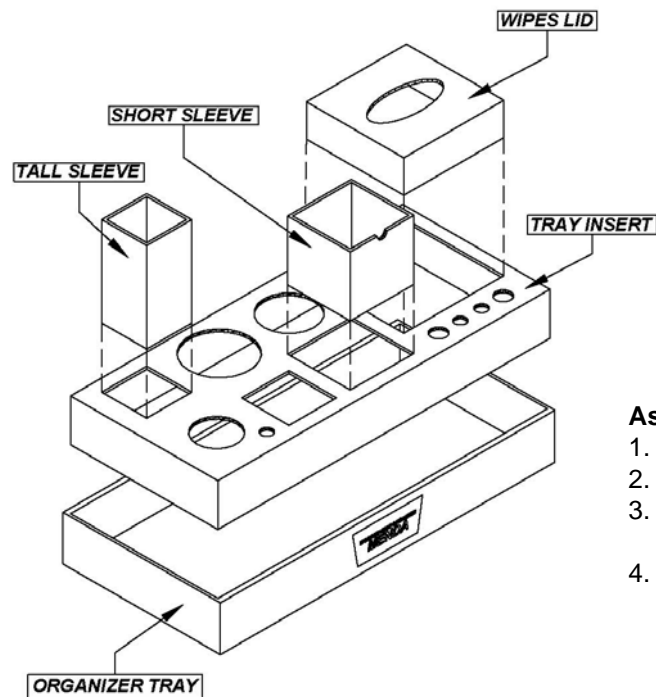

### ASSEMBLY



#### Assembly Instructions:

1. Fold up organizer tray
2. Fold up the insert & place in tray
3. Fold up the short sleeve and tall sleeve and place them into the organizer insert as shown
4. Place overlay label on the front lip of the box.

### Description

- Ideal for improving the appearance of the workstation and standardizing the placement of tools at any workstation.
- Can be used for various items which are used on the workstation, such as MENDA dispensing bottles, lotion, flux bottles, solder spools, cutters, tweezers, wash bottles and various other workbench accessories.
- Dimensions: 16-7/8"W x 8-1/8"D x 2-3/8"H
- Made from an Extruded Conductive polypropylene Plastek™ material, making it ideal to properly set up and standardize any ESD workstation.
- Conductive 10E2 – 10E4 ohms per ANSI/ESD S11.11 – material provides reliable path-to-ground
- Superior strength and durability; made from extruded, high impact polypropylene materials
- Chemical and moisture resistant
- Economical alternative to injection molded products
- Made in America

35872	Assembly Workstation Organizer, Kit
35873	Assembly Workstation Organizer, Box Only



Made in America

**Call us for your custom needs!**

# MENDA

### Assembly Workstation Organizer

Correct Products, Inc.  
 Richardson, Texas  
[www.correctproducts.com](http://www.correctproducts.com)